



COUNTRY FLAME TECHNOLOGIES

INSTALLATION, OPERATION, AND MAINTENANCE MANUAL

INGLENOOK FIREPLACE GAS LOG SET MODEL INGLS 24-N OR INGLS 24-P NATURAL GAS OR PROPANE CONVERSION KIT



USA & CANADA TEST:
Harmonized ANSI Z21.60-2003
CGA 2.26-MO3 & CAN/CGA-21.7.M91

TESTED BY:
WARNOCK HERSEY



WARNING: If the directions contained in this manual are not followed exactly, a fire or explosion may result causing property damage, personal injury or loss of life.

IF YOU SMELL GAS FOR YOUR SAFETY

- Do not light any appliance.
- Do not touch electrical switches; do not use the phone in your building.
- Immediately call the gas company from a neighbor's phone.
- Follow gas company instructions.
- Call the Fire Department if Gas Company doesn't answer.

FOR YOUR SAFETY

Do not store or use gasoline or any flammables (vapors or liquids) in the vicinity of this or any other appliance.
Installation and repair must be performed by a qualified service person or gas supplier.

Country Flame Technologies
A Division of American Products, LLC
900 George Street
Marshfield, MO 65706
417-859-0990
417-859-0192
www.countryflame.com

© 2004

COUNTRY FLAME

TABLE OF CONTENTS

INTRODUCTION	4
SAFETY INFORMATION	5
INSTALLATION PREPARATION	6
CLEANING	6
NEW INSTALLATION	6
INGLENOOK PARTS REMOVAL	7
INSTALLATION, GAS LINE	8
PRESSURE TESTING	8
SIT 820 NOVA mV GAS CONTROL VALVE	9
INGLENOOK GAS LOG KIT	9
INSTALLATION FACTOR A:	9
INSTALLATION FACTOR B:	9
LIQUID PROPANE CONVERSION KIT	10
NATURAL GAS CONVERSION KIT	10
ALTITUDE LIMITATIONS	10
INGLENOOK GAS LOG KIT SPECIFCATIONS	11
SHUTTER SETTING	11
INSTALLATION, BURNERS	12
INSTALLATION, EMBERS	16
INSTALLATION, GAS LOGS	17
OPERATING INSTRUCTIONS	21
LIGHTING INSTRUCTIONS	21
TO TURN OFF GAS TO INGLENOOK	21
FIRST FIRE	21
MAINTENANCE INSTRUCTIONS	22
SPECIFIC TASKS	22
CLEANING BURNERS AND CONTROLS	22
REPLACE OLD EMBERS	22
CHECK FLAME AND PILOT	22
CHECK VENT SYSTEM	23
GENERAL INSPECTIONS	23
GENERAL VENT INSPECTION	23
GENERAL CLEANING REQUIREMENTS	23
GENERAL SAFETY	23
GENERAL PERIODIC INSPECTIONS	24
GENERAL CLEANING, PAINTED SURFACES	24
GENERAL CLEANING, PLATED SURFACES	24
MAIN ORIFICES	24
GAS FLAME INSPECTION	24
PROPANE FUEL CONVERSION INSTRUCTIONS	25
NATURAL GAS CONVERSION	27
THERMOSTAT/FAN CIRCUIT	27
TROUBLESHOOTING INSTRUCTIONS	28
TROUBLESHOOTING INSTRUCTIONS (cont'd)	29
TROUBLE-SHOOTING GUIDE	30

TABLE OF CONTENTS

NOVA mV SET-UP GUIDE	31
SAFETY LABEL.....	32
REPLACEMENT PARTS – INGLS 24N or INGLS 24P	33
LIMITED 10 YEAR WARRANTY	34

INTRODUCTION

THANK YOU and CONGRATULATIONS on the purchase of a new Inglenook gas log kit. The Inglenook fireplace is a solid fuel (wood only) burning appliance; however, many Country Flame customers requested the capability to convert their Inglenook fireplace to a natural gas or a propane gas log set instead of being required to use solid fuel. Inglenook owners are already part of the thousands of members referred to as Country Flame Family. To ensure continued product satisfaction, Country Flame designed, developed and manufactured the new Inglenook gas log set for Inglenook owners that want to convert their product from wood to gas. This Country Flame gas log set is the only product certified for use and can only be used in the Inglenook solid fuel fireplace. Using this certified Country Flame gas log set in the Inglenook fireplace protects the environment while obtaining maximum value from the purchase.

Each employee at Country Flame pledges to ensure every one of our customers has our continuing commitment of product support. Country Flame dedicates its product support to ensuring a customer obtains the greatest level of satisfaction from the proper use of our products. Thank you for continuing to select Country Flame to satisfy your hearth needs. We look forward to hearing from you, as this product becomes part of your home heating solution.

Country Flame wrote this manual to assure proper installation, proper maintenance, and correct operation of a gas log set in an Inglenook Solid Fuel (wood) fireplace. Once converted, the Inglenook Fireplace CANNOT be used to burn solid wood fuel unless it is re-converted back to solid fuel operation. In the event of any questions or confusion on the installation or operation of the Inglenook, contact Country Flame or a certified professional before undertaking the installation or operation of this appliance.

Country Flame wishes you a lifetime of warmth and happiness.

SAFETY INFORMATION

- ⚠ The Inglebrook gas log kit is designed to be installed only in an Inglebrook solid-fuel burning fireplace that has a working flue constructed of noncombustible materials.
- ⚠ Maintain a minimum permanent free flue opening of 50.2 square inches provided by the Inglebrook fireplace chimney and chimney damper system to vent flue gasses. Maintain this permanent free flue opening by keeping the damper in the fully open position during gas log use. See FIGURE 2.
- ⚠ Solid fuels will not be burnt in the Inglebrook fireplace while the Inglebrook gas log set is installed.
- ⚠ The Inglebrook fireplace damper is to remain the open position, see FIGURE 2, at all times during the use of the Inglebrook gas log set. Attach a damper clamp as shown in this manual.
- ⚠ A fireplace screen must be in place at all times when operating the Inglebrook gas logs. The Inglebrook combustion air vent is to be installed and open during gas log burning.
- ⚠ The Inglebrook and the Inglebrook gas valve is to be disconnected from the gas supply line during any gas supply system testing where test pressures exceed ½ pounds per square inch gauge (psig) (3.5 kPa).
- ⚠ Do not use the Inglebrook gas log system if any part of the system has been under water. Immediately contact a certified service technician to inspect the appliance. Replace any part(s) of the control system or the gas valve that has been under water.
- ⚠ Do not store or use gasoline or other flammables near this appliance.
- ⚠ Do not place clothing or flammable material on or near this appliance.
- ⚠ Due to high operating temperatures, this appliance should be located out of high traffic areas and away from furniture and draperies.
- ⚠ Children and adults should be alerted to the hazards of high surface temperatures. Maintain safe clearances (stay away) to avoid burns or clothing ignition.
- ⚠ Always supervise young children playing in the same room as this operating appliance.
- ⚠ Any safety screen, guard or other parts removed for servicing this appliance must be replaced prior to operation.
- ⚠ A CERTIFIED GAS TECHNICIAN SHOULD PERFORM INSTALLATION AND REPAIR. ONCE INSTALLED, AN ANNUAL INSPECTION NEEDS TO BE PERFORMED BY A CERTIFIED GAS PROFESSIONAL.
- ⚠ The interior of a gas stove is subject to surface rust due to moisture in the combustion air as well as condensation created during the initial warm up and firing of the gas appliance. At a minimum, annually clean and repaint the interior surfaces of the firebox to prevent deterioration. More frequent cleaning may be required due to carpet lint, bedding material, dust, etc. being drawn into the appliance. It is imperative that this appliance's control compartment, burners, circulating air system is kept clean.
- ⚠ **WARNING:** IMPROPER INSTALLATION, ADJUSTMENT, ALTERATION, SERVICE OR MAINTENANCE CAN CAUSE INJURY OR PROPERTY DAMAGE. REFER TO THIS MANUAL FOR ASSISTANCE OR FOR ADDITIONAL INFORMATION CONSULT A QUALIFIED INSTALLER, SERVICE AGENCY, OR GAS SUPPLIER.
- ⚠ ALWAYS use high temperature rated silicone or sealing compound at 600°F (316°C) or higher.
- ⚠ The Inglebrook gas logs are designed to operate with the doors fully open or fully closed.
- ⚠ **WARNING:** AN INGLEBROOK GAS LOG KIT IS DESIGNED FOR A VENTED INGLEBROOK FIREPLACE WITH AN 8 INCH DIAMETER CHIMNEY PIPE A MINIMUM OF 8 FEET TALL TO A MAXIMUM OF 50 FEET TALL. REFER TO PAGE 32 AND 33 OF THE INGLEBROOK OWNER'S MANUAL FOR PROPER CHIMNEY INSTALLATION.

PLEASE KEEP THESE INSTRUCTIONS FOR FUTURE REFERENCE

INSTALLATION PREPARATION

IMPORTANT NOTE: Read and comprehend all instructions in this manual before beginning installation. Failure to follow these installation instructions may result in a fire hazard, may result in personal injury, voids the warranty, and may affect a homeowner's insurance policy.

CLEANING

The Inglenook fireplace requires advanced preparation before installation of a gas log set is completed. The amount of preparation time will depend greatly on whether the Inglenook fireplace has been in use (and for how long) or whether this is a new installation. If the Inglenook has been in use, it will necessary to contract with a professional cleaning service, such as a chimney sweep. Professional cleaning will be required both of the Inglenook's firebox and the chimney system. Once cleaning is complete, perform a system check. This system check should ensure the damper is operating freely and properly and that the combustion air vent has no blockage allowing free airflow into the combustion chamber.

NEW INSTALLATION

For first time Inglenook fireplace installations, complete ALL installation instructions contained in the installation, operation, and maintenance manual that was provided with the Inglenook fireplace before beginning installation of the Inglenook gas log set. Failure to adhere to all installation requirements for an Inglenook solid fuel fireplace can create installation or operational problems when converting or operating the Inglenook gas log system. Contact a local authorized dealer or Country Flame to resolve any confusion or issues associated with installation. To maintain a valid Country Flame warranty, the use of a certified installer is required.



Once installation of the Inglenook solid fuel fireplace is complete, the installer can begin installation of the Inglenook gas log kit. The following pages take the installer through systematic requirements of this gas log installation procedure. In the event there is any confusion or questions, please contact a local authorized dealer or Country Flame direct.

INGLENOOK PARTS REMOVAL

Once cleaning or installation of the Inglebrook solid fuel fireplace is complete, it is time to remove some parts that will not be required for gas operation. FIGURE 1 identifies each of these parts and TABLE 1 lists each of these parts along with the Country Flame Part Number. Use TABLE 1 as a check sheet when removing these parts. Once removed, the wood burning parts need to be properly packed and stored away for potential future use. The homeowner should ensure proper storage of the Inglebrook solid fuel parts. Future conversion of the Inglebrook gas log system back to a solid wood fuel system will require the use of these parts. If the parts are lost, damaged, or worn, contact Country Flame or an authorized dealer to obtain new parts before attempting wood burning operations in the Inglebrook fireplace again.

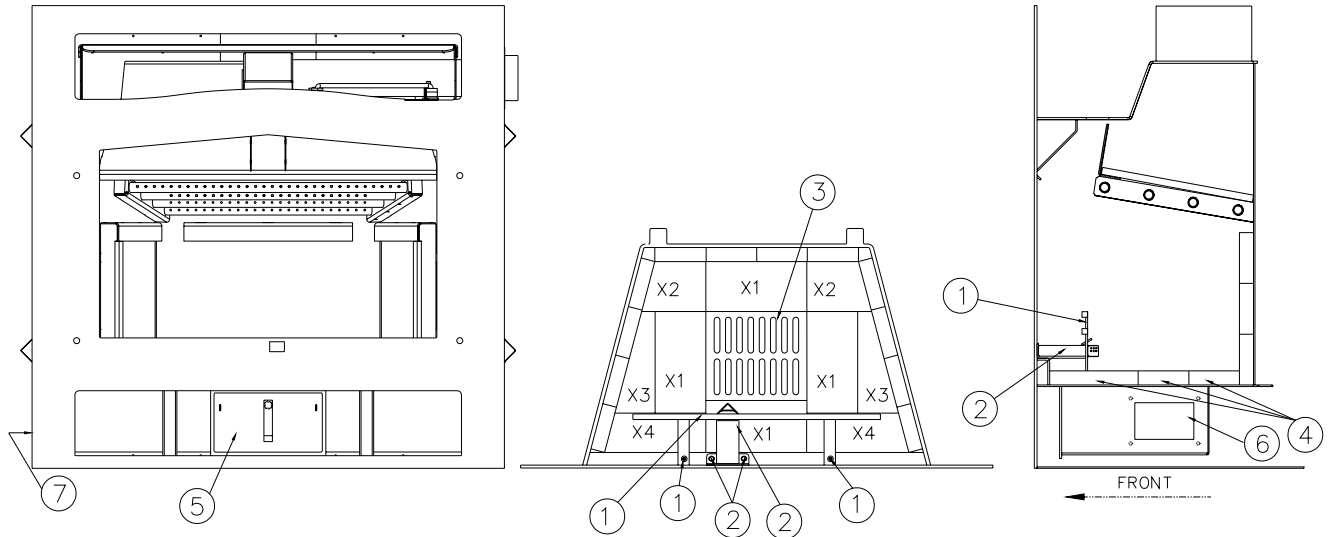

FIGURE 1: INGLENHOOK SOLID FUEL PARTS REMOVAL

TABLE 1 should be used as a checklist to ensure all solid (wood burning) fuel parts are removed. Once removed, these parts should be stored for potential future conversion from gas logs back to solid wood burning fuel.

FIGURE 1 ITEM	PART DESCRIPTION	PART NUMBER	REMOVED
(1)	Log Retainer	IN-201	
(1)	¼ by 20 by ½ Security Bolt	PP-1225	
(1)	¼ by 20 by ½ Security Bolt	PP-1225	
(2)	Starter Air Intake Assembly	IN-54	
(2)	¼ by 20 by ½ Bolt HHCS	PP-766	
(2)	¼ by 20 by ½ Bolt HHCS	PP-766	
(3)	Ash Grate	IN-47	
(4)	Bottom Fire Brick #X1, 4 each	PP-868	
(4)	Bottom Fire Brick #X2, 2 each	IN-202	
(4)	Bottom Fire Brick #X3, 2 each	IN-203	
(4)	Bottom Fire Brick #X4, 2 each	IN-204	
(5)	Ash Pan Box	IN-93	
(5)	Ash Pan Handle	PP-1192	
(6)	Ash Pan Compartment Side Plate	IN-72	
(6)	#8 by 32 by 3/8 TEK SMS, 4 each	PP-159	
(7)	Gas Line Knock Out (left side)	disposable	

TABLE 1: INGLENHOOK SOLID FUEL PARTS REMOVAL

INSTALLATION, GAS LINE

Installation of the Inglenook fireplace and the Inglenook gas log kit must conform to National Standards, NFPA 54 (natural gas) or NFPA 58 (propane). The installation of gas line and leak testing must conform to the National Fuel Gas Code ANSI Z223.1 (United States) and CAN/CGA B-149 (Canada) Installation Code and all local codes and gas supplier restrictions. The Inglenook fireplace has been tested and approved for installation using a (7/8" O.D. / 1/2" I.D.) Model #1650 N Dormont Flex Connector supplied with the unit. A licensed plumber will be required to install a gas line and a supply cut-off valve to the Inglenook fireplace. Purge air from the gas supply line before connection is made to the Inglenook fireplace. The shut-off connection between the gas line and the Inglenook gas logs will be installed similar to that shown in FIGURE 2. Do not install gas supply lines in chimneys, gas vents, dumb waiters, elevator shafts, clothes chutes, or other air ducts. Gas piping should be sloped 1/4" for every 12 feet of horizontal run. The slope will run from the gas meter down to the Inglenook. Horizontal runs of gas piping require mechanical support every 10 feet by suitable gas pipe hangars or straps. Install drip leg traps where condensate might accumulate in the gas supply line. Verify local code requirements for sediment traps. Traps collect moisture and sediment that might otherwise block the Inglenook gas log orifices or valves. Blockages can prevent the gas log system from operating properly. Depending on the length of gas line installed from the gas company meter to the Inglenook gas control valve, different size piping is required. Check with the local gas company for requirements but NEVER use plastic or galvanized pipe. Always follow the flow direction marked on all gas line connectors. Once installation of the gas line is complete, the Inglenook fireplace damper setting should remain in the fully open position as shown in FIGURE 2.

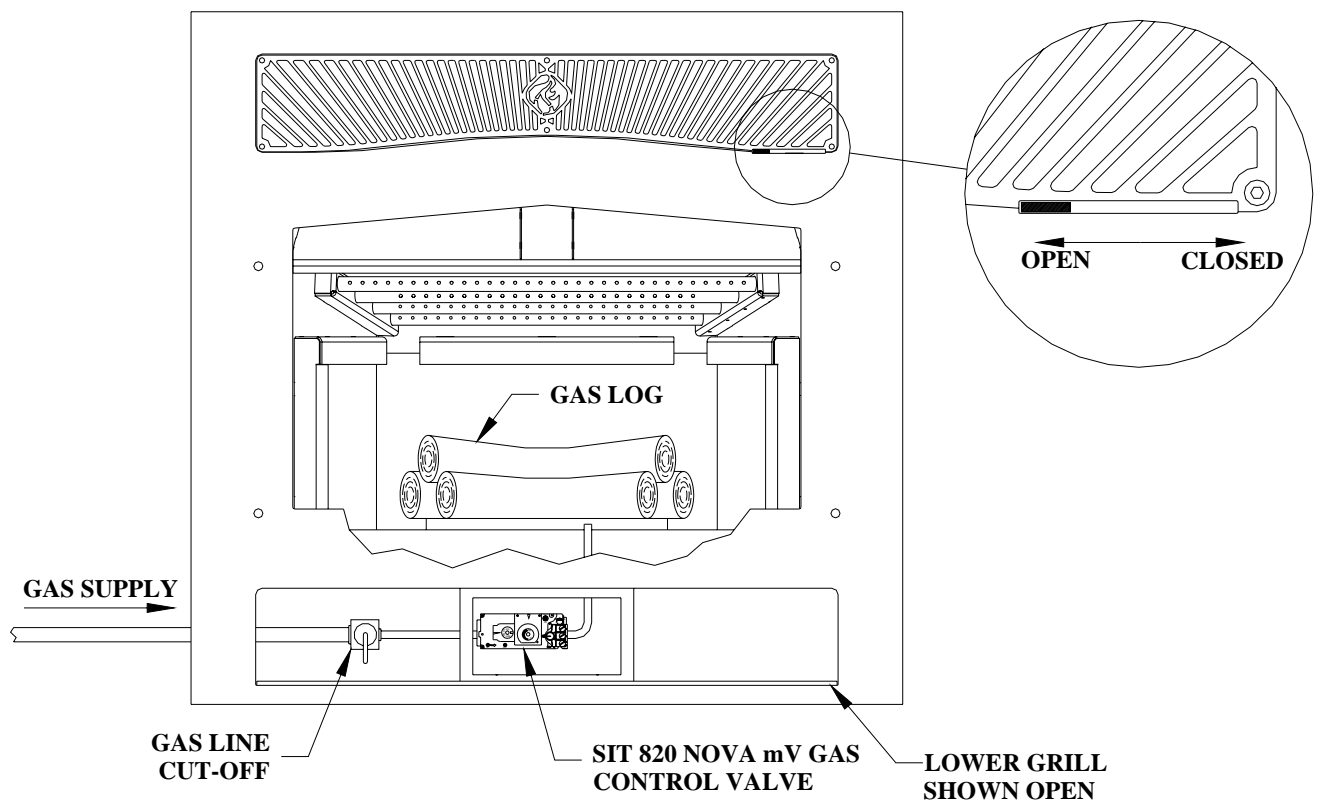

FIGURE 2: INGLENOOK GAS LINE INSTALLATION

PRESSURE TESTING

The Inglenook and its control valve are to be isolated from the gas supply piping system by closing its individual cut-off valve during any pressure testing of the gas supply piping system at test pressures equal to or less than 1/2 psig (3.5 kPa). If pressures above 1/2 psig (3.5 kPa) are present, the Inglenook and its gas valve must be disconnected from the gas supply piping during any pressure testing.

SIT 820 NOVA mV GAS CONTROL VALVE

The SIT 820 NOVA mV gas control valve is part of the drop in assembly provided with the Inglebrook gas log kit. This unit sits in the bottom of the Inglebrook fireplace with the SIT 820 extending through the ash grate opening. The SIT 820 NOVA mV gas control valve, when properly located will be visible through the opening in the ash pan housing. Remember, the grate and ash pan were removed in previous steps parts. The SIT 820 control valve is connected to the gas supply cut-off valve. FIGURE 3 shows the valve with an explanation of its features as follows:

1. The left knob controls the ON/PILOT/OFF functions.
2. The right knob controls the manifold pressure to the burners and is labeled HI/LO.
3. There is an adjust screw for the pilot flame that should only be adjusted by a certified technician.
4. The SIT 820 has an input pressure test point labeled IN.
5. The SIT 820 has an output pressure test point labeled OUT.

To use either of the pressure test points to measure pressure requires test equipment and knowledge required by a certified service technician. Improperly adjusting the pilot adjust or the manifold pressure can cause damage to the SIT 820 control valve and should only be accomplished by a certified professional. For lighting instructions, refer to the section on first fire in this manual or on the units control panel.

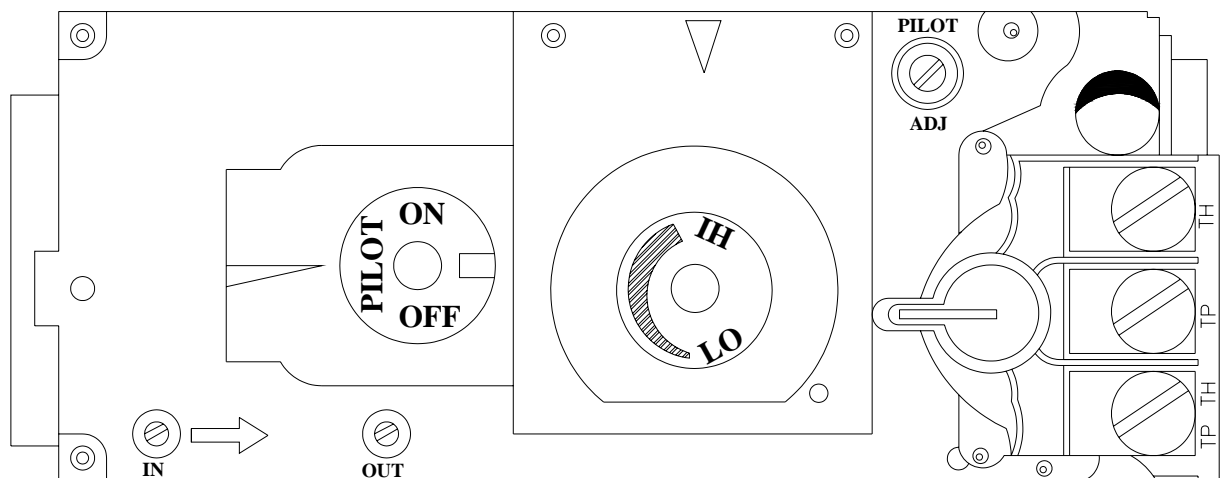

FIGURE 3: SIT 820 mV NOVA GAS VALVE

NOTE: TP stands for thermopile, TH for thermostat, and TP TH for thermopile and thermostat. See FIGURE 28.

INGLEBROOK GAS LOG KIT

All the Inglebrook fireplace solid fuel parts should now be removed and properly stored. The gas log kit is unpacked and ready for installation; however, before starting the installation, the installer should answer two important questions. These two questions are called FACTOR A and FACTOR B and are defined as follows:

INSTALLATION FACTOR A:

Factor A defines the type of gas log fuel that will be used with a specific installation. The homeowner and installer must verify that the expected fuel usage and the type of fuel the gas log kit is designed to use are one in the same. Correct any discrepancy between the gas log kit's fuel type and the fuel being used.

WARNING: Do not use a Country Flame gas log kit with the wrong fuel. Improper fuel use is dangerous to facilities and occupants and immediately voids Country Flame's product warranty. Consult a certified installer or authorized dealer.

INSTALLATION FACTOR B:

Factor B requires an inventory of the gas log kit to be completed. This inventory will ensure all kit components are present and not damaged. Contact Country Flame or an authorized dealer to resolve any

discrepancy or to obtain necessary parts to replace any missing or damaged components. TABLE 2 provides a gas log kit part's list for both natural gas and propane kits. Use the appropriate version of TABLE 2 as a check sheet while verifying the presence and condition of each kit part. Again, contact Country Flame or an authorized dealer to resolve any issues before converting the Inglenook gas log set to a different fuel.

LIQUID PROPANE CONVERSION KIT

ITEM	QTY	PART NUMBER	ITEM DESCRIPTION
Regulator	1	GC-3905-01	SIT 820 NOVA mV Gas Valve
Pilot	1	BV-4613	#51 DMS Pilot Injector Orifice
Front Spud Orifice	1	IN-6513	#31 DMS NG Front Orifice Spud
Rear Spud Orifice	1	IN-6514	#43 DMS NG Rear Orifice Spud
Conversion Label	1	IN-6521	Conversion LP to NG
Instructions	1	IN-6523	Conversion Kit Instructions

TABLE 2a: IN-6504 CONVERSION KIT (to natural gas)

NATURAL GAS CONVERSION KIT

ITEM	QTY	PART NUMBER	ITEM DESCRIPTION
Regulator	1	GC-3906-01	SIT 820 NOVA mV Gas Valve
Pilot	1	BV-4614	#35 DMS Pilot Injector Orifice
Front Spud Orifice	1	IN-6515	#48 DMS LP Front Orifice Spud
Rear Spud Orifice	1	IN-6516	#55 DMS LP Rear Orifice Spud
Conversion Label	1	IN-6522	Conversion NG to LP
Instructions	1	IN-6524	Conversion Kit Instructions

TABLE 2b: IN-6503 CONVERSION KIT (to propane)

It should be noted that conversion from one type of fuel to another type of fuel requires the adjustment of both the front and rear burner air shutters. Refer to the specifications in this manual and verify local codes and other site-specific conditions to ensure proper setting of all parameters involved in the fuel conversion process.

ALTITUDE LIMITATIONS

In the United States, the Inglenook gas log input ratings are determined at sea level operation. The Inglenook gas logs do not require any operational changes up to and including 610 meters. Gas log operations above 610 meters require the Inglenook burners to be set as stated in TABLE 3. Exception: As permitted by the authority having jurisdiction.

Canadian input ratings of this unit are determined at seal level operation. No Inglenook input rating needs to be change up to 4,500 feet above sea level in Canada. Installation of the Inglenook gas logs at altitudes above 4,500 feet is subject to field test of the individual installation and approval by the local authority having jurisdiction.

INGLENOOK GAS LOG KIT SPECIFCATIONS

TABLE 3 provides specifications for both Ingleenook natural gas and propane gas fuel log kits. The installer and homeowner must understand the differences in these kits both for the type of fuel being used and the impact that altitude has on specific fuel operations. Test procedures for verifying the fuel pressures are provided as part of the SIT 820 control valve operation provided in this manual. Contact a local authorized dealer or Country Flame direct to resolve any issues with specifications or the requirements thereof.

TABLE 3: INGLENOOK LOG SET SPECIFICATIONS

DESCRIPTION	NATURAL GAS	PROPANE GAS
INPUT RATING (Btu/hr) 0 - 610 Meters*	65,000	65,000
MIN INPUT RATING (Btu/hr) 0 - 610 Meters	42,600	43,000
ORIFICE SIZE (DMS) 0 - 610 Meters front/rear	31/43	48/55
MINIMUM SHUTTER SETTING (inches)	0	1/8
PILOT ORIFICE (DMS)	51	35
INPUT RATING (Btu/hr) 610 - 1370 Meters	59,000	58,700
ORIFICE SIZE (DMS) 610 - 1370 Meters	32/44	49/56
MANIFOLD PRESSURE (Inches of Water Column)	3.5	10.0
MANIFOLD PRESSURE, Low Setting (Inches of W.C.)	1.4	4.2
MINIMUM INLET PRESSURE (Inches of W.C.)	4.5	11.0
MAXIMUM INLET PRESSURE (Inches of W.C.)	7.0	14.0

*ANSI standards are SAFETY STANDARDS not PERFORMANCE STANDARDS. Performance standards are defined as efficiency standards, A.F.U.E ratings, and efficiency test protocol that is established by the United States Department of Energy.

SHUTTER SETTING

Verify that the adjustable burner air shutter is set according to TABLE 3. FIGURE 4 shows the rear burner assembly (Item B) and the adjustable burner air shutter (Item A). Loosen the locking screw that holds the air shutter in place. Use a proper sized drill bit shank to set the correct opening of the air shutter. Retighten the locking screw. To set the burner air shutter for the front burner assembly, repeat the process.

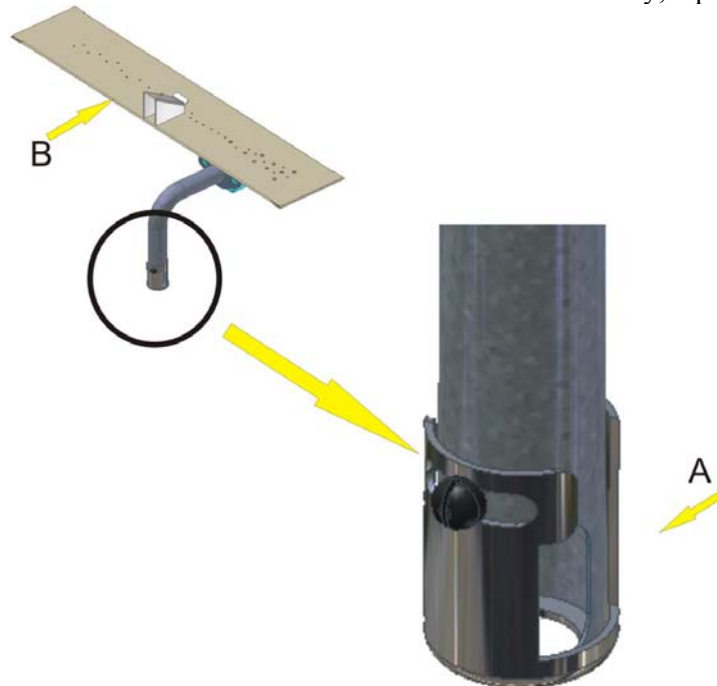

FIGURE 4: ADJUSTABLE BURNER AIR SHUTTER

INSTALLATION, BURNERS

STEP 1:

Once TABLE 1 has been filled in, once all parts have been removed from the Inglenook Fireplace and properly stored, then installation of the gas burner system can begin. FIGURE 5 shows the valve plate assembly that is to be installed in the bottom of the Inglenook in the direction of the arrows. This assembly includes the gas valve and gas line with front and rear gas orifices, the gas valve frame, the base plate, and the pilot valve assembly. This assembly should be placed through the grate opening and should sit squarely in the grate hole. If this assembly is not sitting square and flat in the grate recess, the rest of the burner installation will not be possible or could be installed incorrectly.

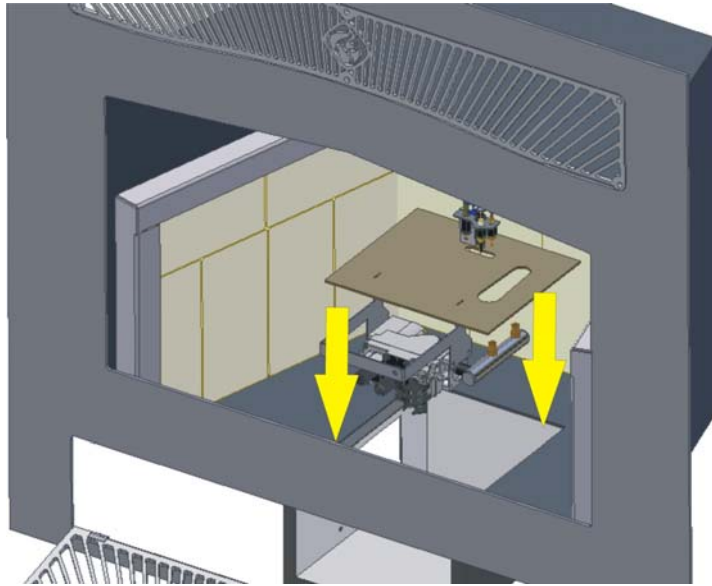

FIGURE 5: BURNER INSTALLATION, STEP 1

FIGURE 6 shows the valve plate assembly installed in the bottom of the Inglenook Fireplace.

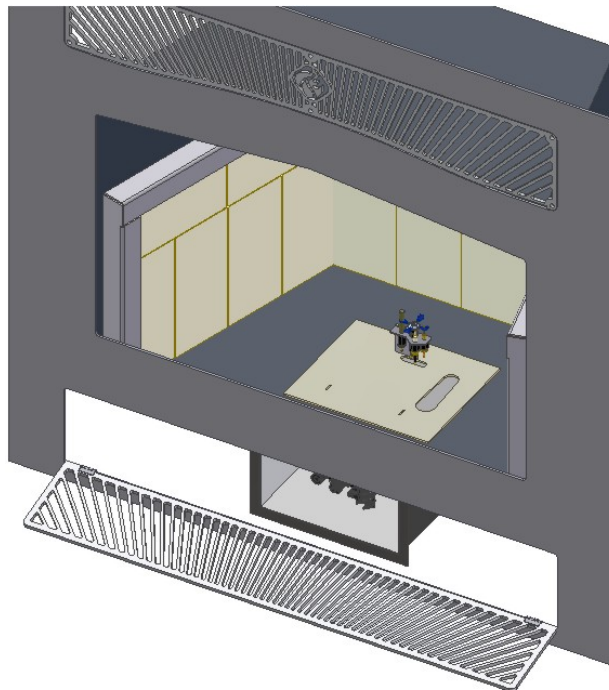

FIGURE 6: STEP 1 COMPLETE

STEP 2:

The ember tray and rear burner assembly are now ready for installation. This assembly includes steel tray framing, the rear burner assembly, including the gas tube. Refer to FIGURE 7 to view the installation of these parts. The installation is in the direction of the arrows shown in FIGURE 7.

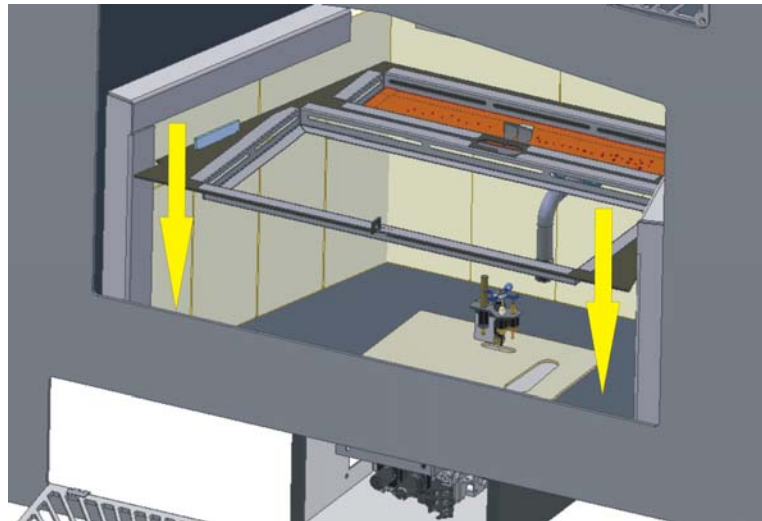

FIGURE 7: BURNER INSTALLATION, STEP 2

FIGURE 8 shows the rear burner tray assembly installed and sitting properly in the bottom of the Inglenook Fireplace. Note that the gas tube of the rear burner must go through the slot in the right side of the floor and sit on top of the rear burner orifice mounted to the lower gas line. FIGURE 9 shows a close-up view of the rear burner adjustable shutter gas tube being set over the gas orifice. It is important that the person performing the installation ensure that the rear burner adjustable shutter tube is located properly over the rear orifice. If the tube is not placed properly over the orifice, the burner assembly will not sit correctly into the Inglenook Fireplace.

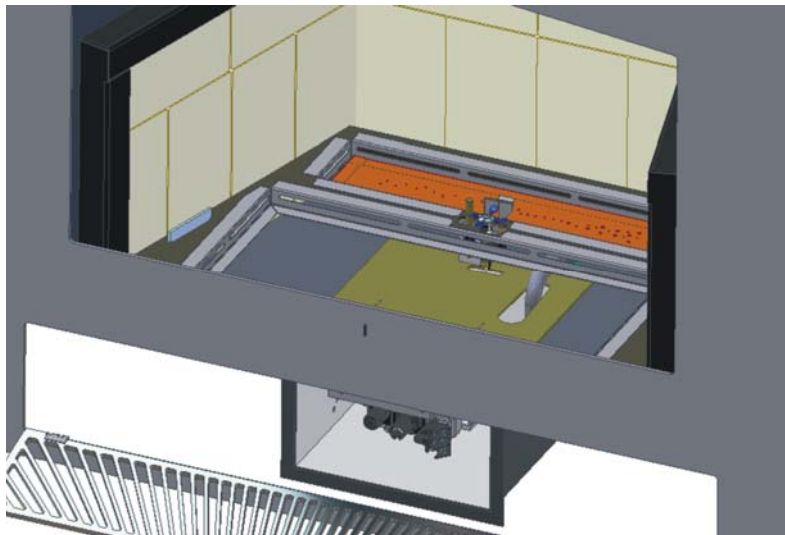

FIGURE 8: STEP 2 COMPLETE

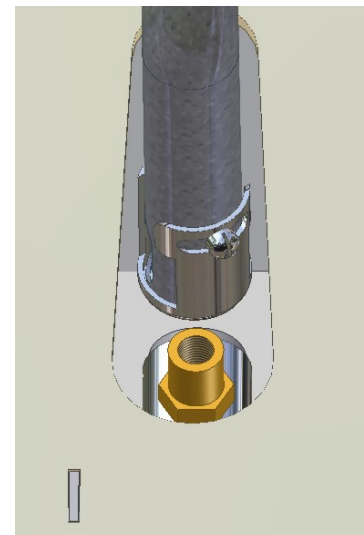

FIGURE 9: GAS TUBE

STEP 3:

The front burner assembly is now ready for installation. This assembly includes the front burner tray and adjustable shutter gas tube. This front burner sits into the only opening left from the part installed in STEP 2. It is important to ensure the adjustable shutter tube sit properly over the front gas orifice so that the front burner tray will sit flat into its opening. FIGURE 10 shows the front burner tray sitting in the Inglenook Fireplace. The front burner plate is blue in color and the rear burner plate is red in color in FIGURE 10.

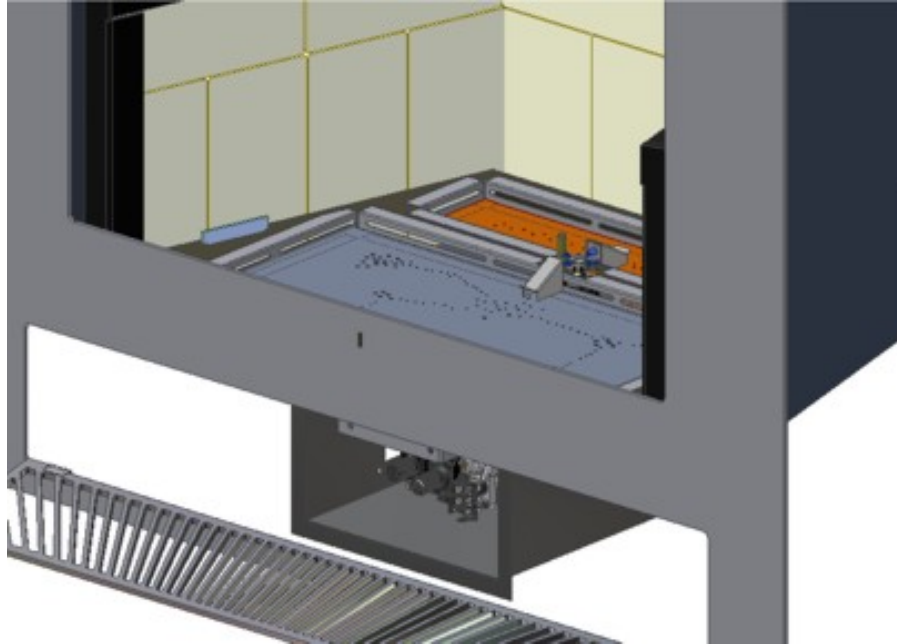

FIGURE 10: STEP 3 COMPLETE

FIGURE 11 shows a close-up view of the adjustable shutter burner tubes and the front and rear gas orifices located along side the gas control valve. These gas tubes can be seen by looking into the ash box compartment where the gas valve assembly is located.

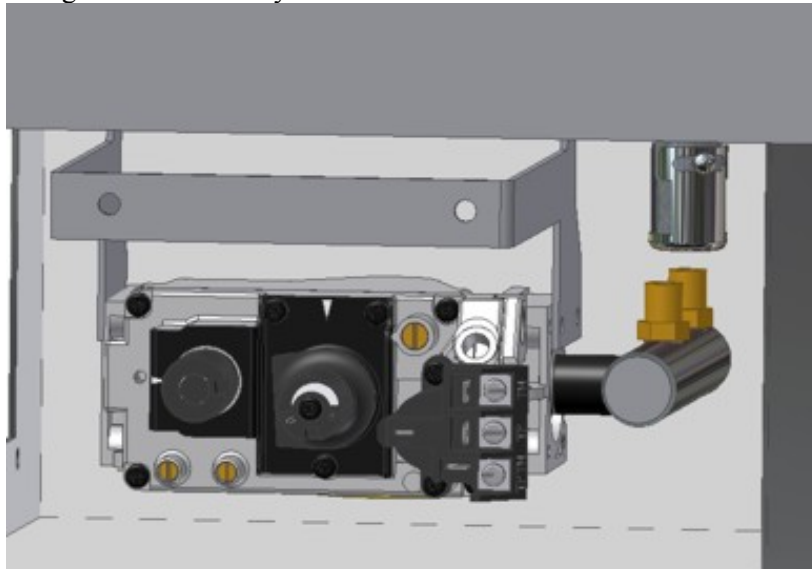

FIGURE 11: BURNER TUBE AND FRONT/REAR ORIFICES

STEP 4:

In STEP 4 the log grate assembly is installed in the Inglenook. This assembly is to be set into the alignment slots provided. FIGURE 12 can be viewed for a look at the proper installation.

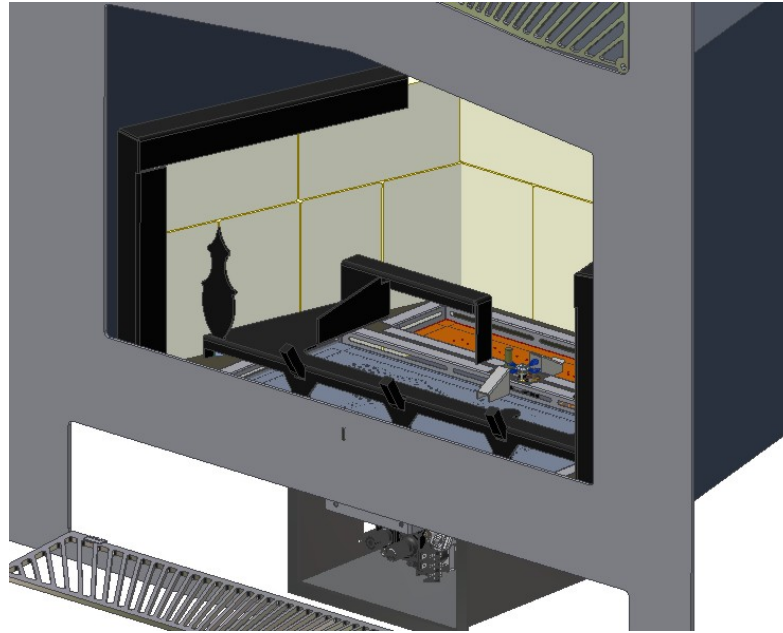

FIGURE 12: LOG RETAINER, STEP 4 COMPLETE

STEP 5:

The control panel is installed in STEP 5. The control panel face plate covers the ash pan housing opening. FIGURE 13 shows the control panel faceplate installed. The control panel overlay, control knobs and switches have not been shown for clarity purposes.

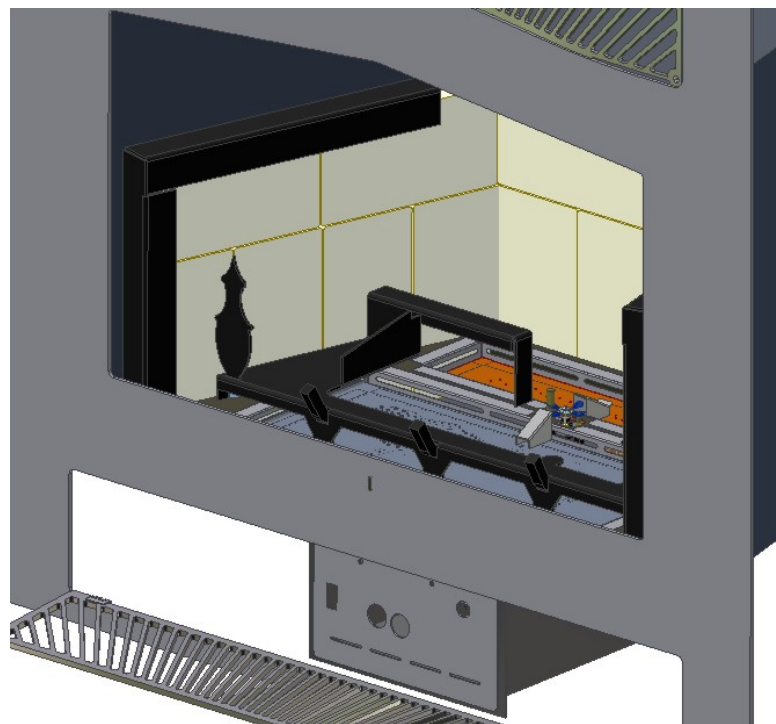

FIGURE 13: CONTROL PANEL, STEP 5 COMPLETE

INSTALLATION, EMBERS

STEP 6:

FIGURE 14 shows the embers installed on the front and rear burner. The embers add a “burning ash effect” to the log system when gas is burnt. Embers also help to break up the gas molecules as they pass through the front and rear burner plates and into the burn chamber where these gas molecules combine with oxygen to ensure complete combustion. From time to time, new embers will need to be purchased.



FIGURE 14: EMBERS, STEP 6 COMPLETE

INSTALLATION, GAS LOGS

STEP 7:

STEP 7 begins the process of installing the six logs that make up the Inglenook log set. It is imperative that these logs are installed exactly as is shown in FIGURE 15 through FIGURE 21. Failure to install the gas logs correctly will cause the Inglenook gas log system to burn inefficiently. Inefficient gas burns can create a significant amount of soot. **WARNING:** Do not reconfigure the logs in any different formation other than what is shown in this manual. Each log can be located in the log retainer or with pins or has pins that need to be installed in it to ensure proper connection to the next log being installed.



FIGURE 15: FIRST LOG INSTALLATION



FIGURE 16: SECOND LOG INSTALLATION

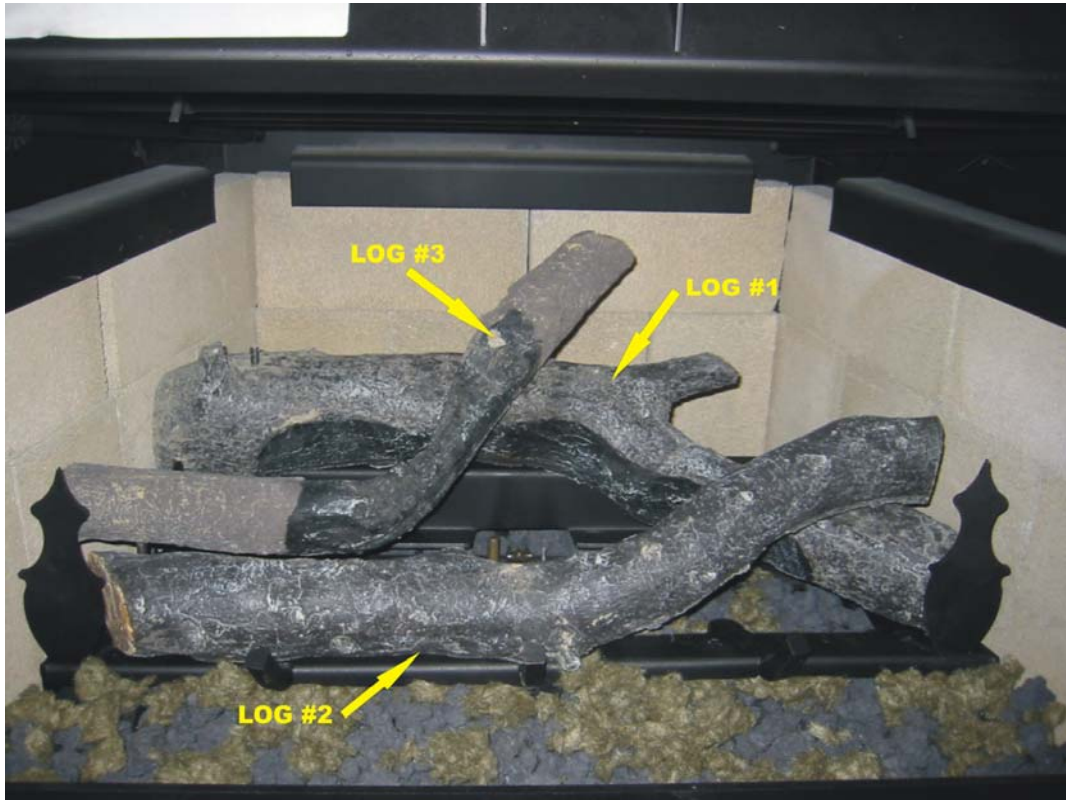

FIGURE 17: THIRD LOG INSTALLATION

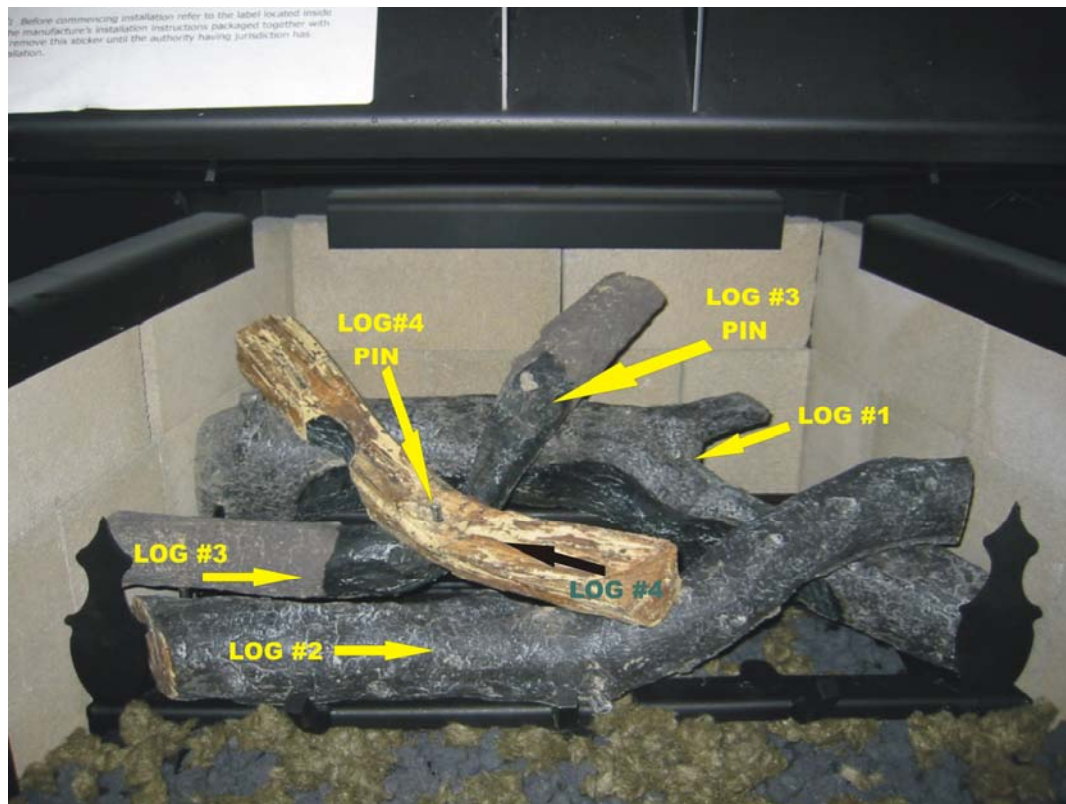

FIGURE 18: FOURTH LOG INSTALLATION

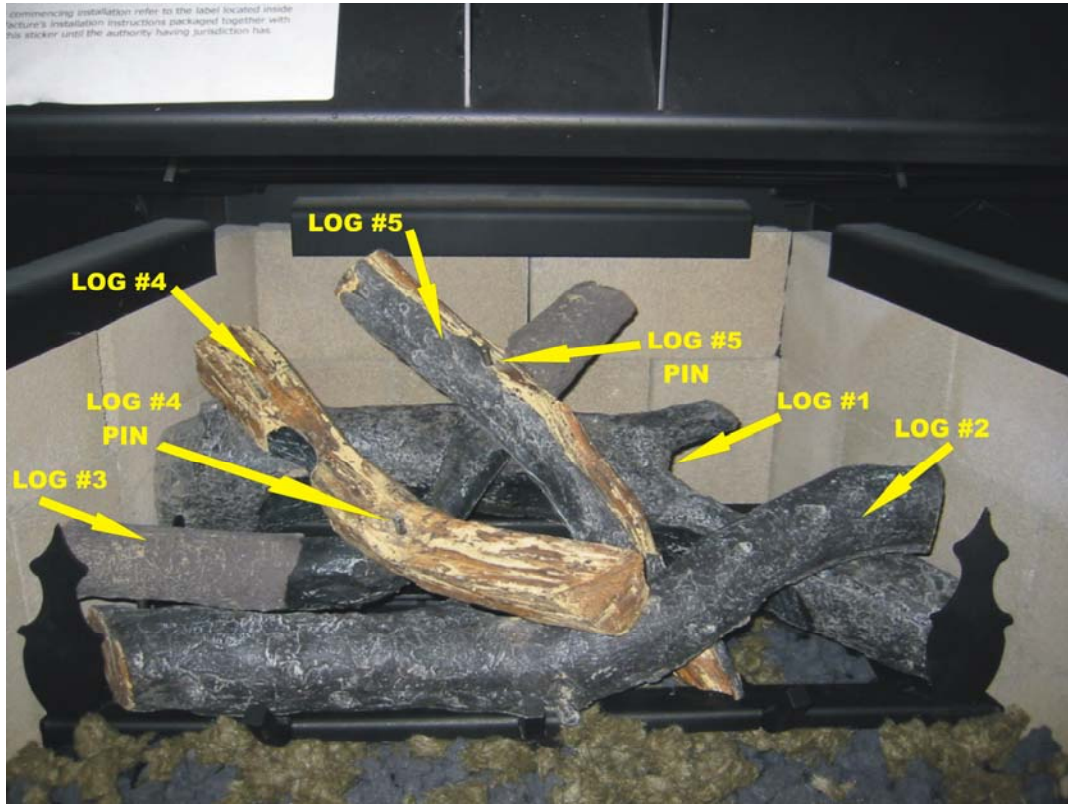

FIGURE 19: FIFTH LOG INSTALLATION

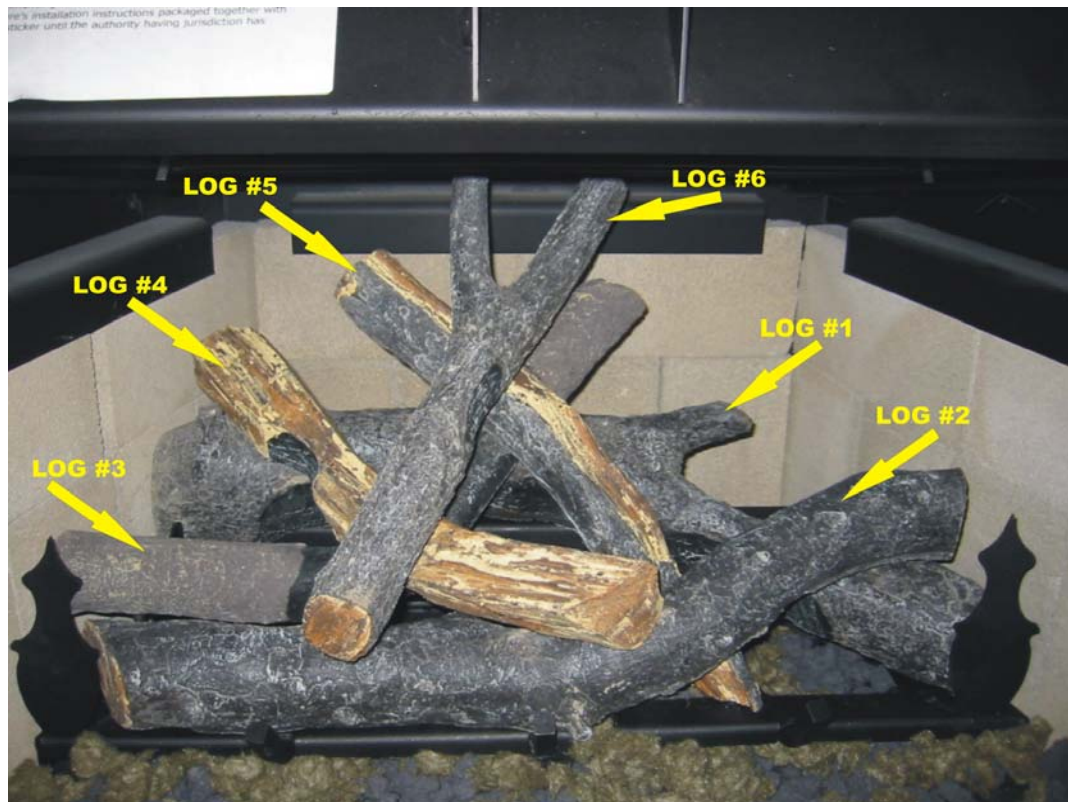

FIGURE 20: SIXTH LOG INSTALLATION



FIGURE 21: COMPLETED GAS LOG INSTALLATION

The Inglebrook gas log system installation is now complete. The installer can proceed to the first fire and lighting instructions on the next page. The entire system should be carefully monitored for the first several fires until the homeowner is convinced that everything is operating properly. If there are any signs that the Inglebrook gas log system is not functioning properly at any time, immediately contact a local Country Flame Dealer, the gas company, or a certified gas technician to have any deficiencies corrected.

OPERATING INSTRUCTIONS

FOR YOUR SAFETY READ BEFORE LIGHTING

WARNING: If you do not follow these instructions exactly, a fire or explosion may result causing property damage, personal injury, or loss of life.

- A. The Inglenook has a pilot light system that must be lit by hand. Follow these instructions exactly, when lighting the pilot.
- B. BEFORE LIGHTING the pilot light, it is important to smell all around the Inglenook for potential gas leaks. Be sure to smell next to the floor because some gas fuel is heavier than air and will settle to the lowest point.

WHAT TO DO IF YOU SMELL GAS

- Do not try to light any appliance.
- Do not touch any electrical switch; do not use any phone in your building.
- Immediately call your gas supplier from a neighbor's phone. Follow the gas supplier's instructions.

- C. If you cannot reach your gas supplier, call the fire department.
- D. Use hand pressure to push in or turn the ON/PILOT/OFF control knob. Do not use a tool. If the control knob will not push in or turn by hand, do not attempt repair. Call a qualified service technician. Attempted repair may result in fire or explosion.
- D. Do not use the Inglenook if any part has been under water. Immediately call a qualified service technician to inspect the Inglenook and replace any part of the control system and any gas control that has been under water.

LIGHTING INSTRUCTIONS

1. **STOP!** Read the safety information above this section.
2. Turn off all electrical power to the Inglenook. Open the Inglenook bottom grill to expose the gas control panel.
3. Push in on the ON/PILOT/OFF control knob slightly and turn clockwise to "OFF."
4. Wait five minutes to clear out any gas. Then smell for gas including near the floor. If you smell gas, STOP! Follow "B" of the safety information above.
5. Turn ON/PILOT/OFF control knob counterclockwise to "PILOT."
6. Push in the ON/PILOT/OFF control knob and hold in. By repeatedly pressing the piezoelectric igniter, a pilot flame should appear. If flame goes out repeat steps 5 thru 10. If flame stays lit, go to Step 10.
7. Push in and turn the ON/PILOT/OFF control knob counterclockwise to "ON."
8. Close the Inglenook bottom grill.
9. Turn on electrical power to Inglenook.
10. The Pilot flame should be visible in the lower center between the logs.
- 11.

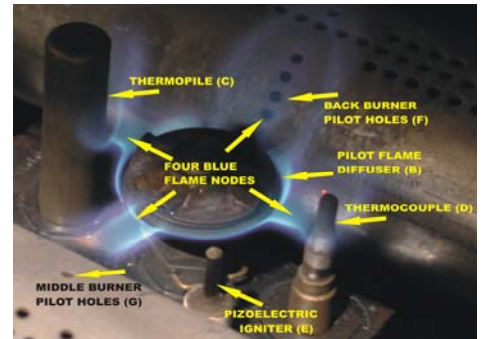
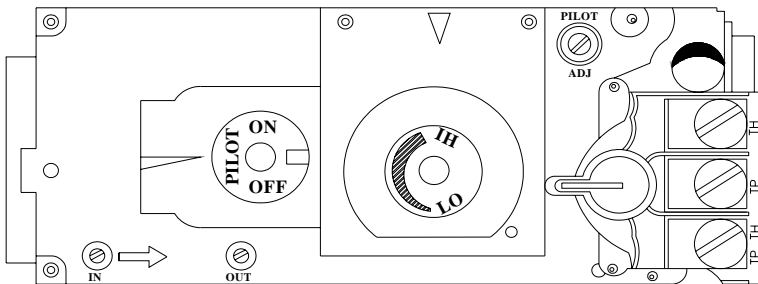

TO TURN OFF GAS TO INGLENOOK

1. When servicing Inglenook, turn off electrical power.
2. Open the Inglenook bottom grill to gain access to control panel.
3. Push in ON/PILOT/OFF control knob and turn clockwise to "OFF." Do not force.
4. Close Inglenook bottom grill.

FIRST FIRE

Reduce odor by ventilating the room the first few times the unit is operated. Burn the first two fires no more than 15-20 minutes. Allow the Inglenook to completely cool between burns. Burn the third fire 30-40 minutes and allow proper cooling time. Operate the appliance according to the instructions contained in this manual.

MAINTENANCE INSTRUCTIONS

The frequency of performing Inglebrook fireplace maintenance depends on site-specific conditions and the frequency of use. Country Flame recommends that a certified service technician perform an annual check-up prior to the start of each heating season. Both specific and general maintenance guidelines are presented in this section. If there are any questions about maintenance or proper service, contact a local authorized dealer, a certified service technician, or Country Flame direct for additional clarification. **IMPORTANT: TURN OFF INGLEBROOK POWER AND SHUT OFF THE GAS BEFORE SERVICING.**

SPECIFIC TASKS

CLEANING BURNERS AND CONTROLS

FREQUENCY: Once during annual inspection.
PERFORMED BY: Qualified service technician.
TASK PERFORMED: Clean the control compartment. Remove and clean logs (careful not to damage ceramic logs). While logs are removed, clean and inspect 2 burners, inspect and clean pilot assembly, and inspect and clean surrounding burner area.

REPLACE OLD EMBERS

FREQUENCY: Once during annual inspection.
PERFORMED BY: Qualified service technician.
TASK PERFORMED: Replace ember material with new ember material. Additional ember material can be purchased from a local authorized Country Flame Dealer. (Only use genuine Country Flame ember material)

CHECK FLAME AND PILOT

FREQUENCY: Periodically.
PERFORMED BY: Qualified service technician or homeowner.
TASK PERFORMED: Visually inspect the burner's flame height and burn patterns. The front and rear burner flames are steady and not lifting or floating away from the burner surfaces. Refer to FIGURE 5d for a picture representation of the proper flame with logs and embers installed. Visually inspect that the pilot light is burning with four blue flame nodes as shown in FIGURE 22, protruding from the pilot flame diffuser. No sputter or blockage of any pilot flame or its four nodes should be visible. If there is any abnormality observed in a flame pattern, contact a local authorized dealer or a certified technician.

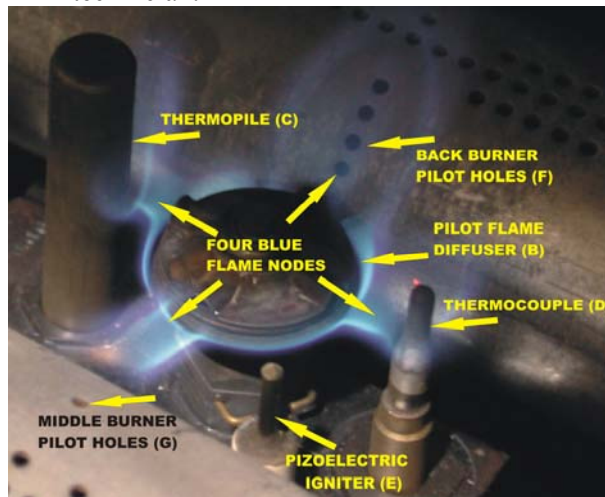

FIGURE 22: STANDING PILOT

CHECK VENT SYSTEM

FREQUENCY:	Once during annual inspection. See General Vent Inspection.
PERFORMED BY:	Qualified service technician or homeowner.
TASK PERFORMED:	Check complete vent system for corrosion, moisture problems, pinholes or broken seals. Remove chimney cap and inspect vent and cap for debris. Ensure clean and open vent system.

GENERAL INSPECTIONS

GENERAL VENT INSPECTION

Inspect the venting system periodically. Additional areas to inspect are as follows:

1. Check areas of the venting system that are exposed to the elements for corrosion. These will appear as rust spots or streaks, and in extreme cases, can be holes. These components must be replaced to ensure the integrity of the system and the safety of the homeowner.
2. Remove the chimney cap and shine a flashlight down the vent. Remove all debris, bird nests, or other foreign material found in the vent system.
3. Check for evidences of excessive condensate, such as water droplets forming in the inner liner, and subsequently dripping out of vent joints. Continuous condensate can cause corrosion of caps, pipe and fittings. Condensation may be caused by having excessive horizontal runs, too many elbows, and exterior portions of the system being exposed to cold weather. Consult a certified professional to correct.
4. Inspect joints, to verify that no pipe sections or fittings have been disturbed or consequently loosened. Also, check mechanical supports such as wall straps or plumbers' tape for proper integrity/support.
5. For all direct vent systems, proper re-assembly and resealing of the vent-air intake system is mandatory. If the vent-air system is disassembled for any reason, reinstall each part per instruction provided for the initial installation.

GENERAL CLEANING REQUIREMENTS

Routinely perform general cleaning of the Inglenook to remove all dust, lint, or other debris that has built up during non-use or in the off-season. Clean the two burners per the specific tasks listed in this manual. Blow out the burners with dry air or carefully vacuum the burners to remove dust or other debris. If any burner damage or degradation is noted, contact a certified professional to verify their working order. No lubrication of any part is required in the Inglenook gas log system.

Country Flame recommends that at a minimum, a certified professional conduct an annual inspection of the venting system. At no time should the Inglenook's combustion air or ventilation air become obstructed. Free airflow is crucial to proper Inglenook operation. The pilot and burner flame patterns require inspection. Flame patterns should not appear suspended above the pilot tube or the burner surfaces. Nor should the pilot or burner flame appear lifeless or smoky in their burn pattern. Have the operational burn patterns checked by a certified professional in the event there is any question about gas burn patterns. Do not use the Inglenook if any part or component of this appliance has ever been under water. Immediately call a certified professional to inspect or replace any part or control system that has been under water.

GENERAL SAFETY

- Always shut off the gas supply and allow the heater to cool down before attempting any service work.
- Always check for gas leaks, after servicing. Do not use a flame to check for gas leaks.
- Always check for correct combustion and ventilation airflow after performing any service.
- Always make sure the heater is away from any combustible or flammable materials.
- Always ensure proper re-assembly and re-sealing of all vent-air intake parts. If any part of the system is disassembled, reinstall those parts per the instructions provided in this manual.

GENERAL PERIODIC INSPECTIONS

Check the venting system annually and make sure the system is clear of any debris. Check flame patterns periodically. Allow 15 minutes for a flame to reach maximum color and height.

GENERAL CLEANING, PAINTED SURFACES

Occasionally dry rag dust the Inglenook to keep the painted surface looking new. Paint can be touched up as needed. Clean any area to be painted with fine steel wool. Remove all trim or cover all trim and controls with masking tape. Then, touch up the stove with Stove Bright® high temperature stove paint. Do not over paint as this will only lead to paint peeling problems.

GENERAL CLEANING, PLATED SURFACES

When cleaning plated trim, use special care to avoid damage. Do not use chemical or abrasive cleaners. Wipe only with a very soft damp cotton cloth to maintain original brilliance. CAUTION: Vigorous wiping may remove or discolor the plated finish.

MAIN ORIFICES

FIGURE 23 shows the valve plate assembly, Item E. This part is installed in the combustion chamber of the Inglenook fireplace. The pilot assembly, Item C, comes preinstalled into Item E. Inspect the wiring of the pilot assembly before installation to ensure all wires are properly connected to the gas valve. The gas control valve, Item D must be plumbed to the gas line cut-off valve that has been installed in the lower chamber of the Inglenook. The front burner spud orifice (Item A) and the rear burner spud orifice (Item B) need to be installed according to the fuel type that will be used. Refer to TABLE 3 to obtain the correct orifice size for both fuel and altitude requirements that site-specific location dictates. Item A and Item B are the front and rear spud orifices. Inspect them for the proper size for the gas being used.

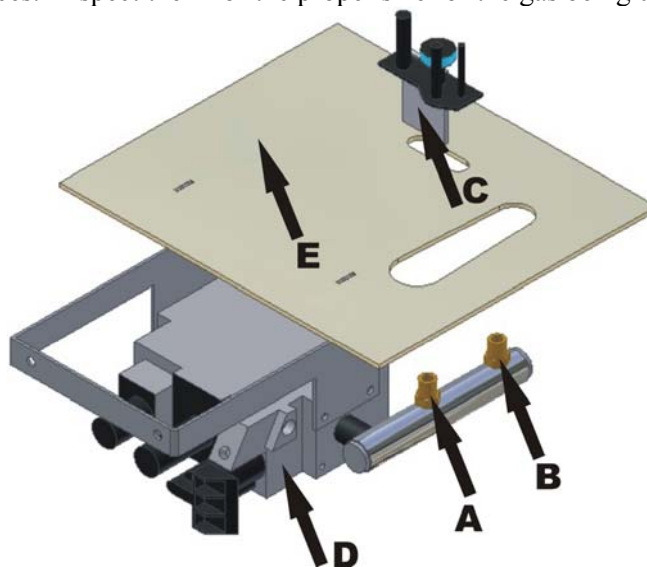

FIGURE 23: BURNER ASSEMBLY

GAS FLAME INSPECTION

The flames will be blue during the first 5 minutes or so but over a period of 15 minutes, the flame will gradually turn yellow. Flame intensity and the glowing logs vary with the specific type of fuel and venting conditions. Refer to FIGURE 5d for a picture that shows a proper flame for natural gas.

IMPORTANT INFORMATION: IT IS NORMAL FOR GAS PRODUCTS, FABRICATED FROM STEEL, TO GIVE OFF SOME EXPANSION AND/OR CONTRACTION NOISES DURING THE START UP OR COOL DOWN CYCLE. SIMILAR NOISES ARE HEARD IN A FURNACE HEAT EXCHANGER OR CAR ENGINE.

PROPANE FUEL CONVERSION INSTRUCTIONS

The Ingleook gas log kit is shipped from the Country Flame factory set for 65,000 Btu/hr natural gas fuel usage; however, conversion kits may be purchased from Country Flame to convert the Ingleook gas log kit to different fuels; propane or natural gas. The Ingleook gas log conversion kit contains different replacement parts depending on the fuel type specified. Fuel conversion requires adjustment to the control valve, the burners, and the pilot system. Refer to TABLE 3 for the correct gas pressures corresponding to the conversion kit being used.

⚠ WARNING: Conversion kits shall be installed by a qualified service agency in accordance with the manufacturer's instructions and all applicable codes and requirements of the authorized agency having jurisdiction. If the information in these instructions are not followed exactly, a fire, explosion or production of carbon monoxide may result causing property damage, personal injury or loss of life. The qualified service agency is responsible for the proper installation of this kit. The installation is not proper and complete until the operation of the converted appliance is checked as specified in the owner instructions supplied with the kit.

- STEP 1** Turn the control knob to the OFF position and turn off the gas supply to the valve.
- STEP 2** Remove control knob extensions from the valve. Allow system to cool before proceeding.
- STEP 3** Remove the control panel by removing the two screws located at the top of the panel. Disconnect the wire from back of piezoelectric igniter. Disconnect wires from on/off switch and variable speed control if required.
- STEP 4** Refer to FIGURE 24 and using a Torx T20 screwdriver, remove and discard the three pressure regulator mounting screws (Item A), the pressure regulator tower (Item B), and the diaphragm assembly (Item C).

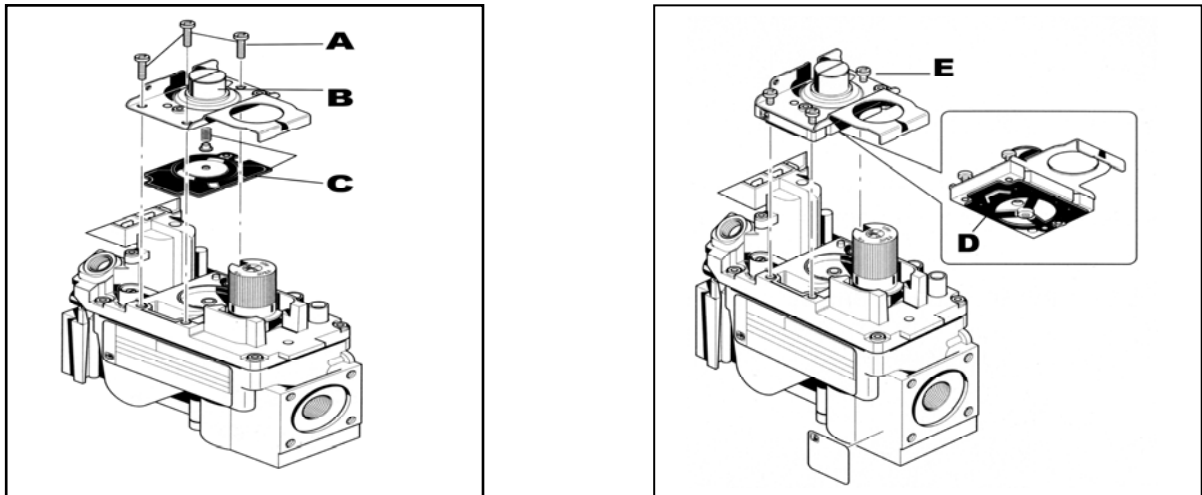

FIGURE 24: SIT 820 NOVA mV GAS CONTROL VALVE

- STEP 5** Refer to FIGURE 24. Ensure that the rubber gasket (Item D) is properly positioned and install the new HI/LO pressure regulator assembly to the valve using the supplied screws (Item E). Tighten screws securely.
- STEP 6** Attach the enclosed "conversion" label near the certification label.
- STEP 7** Re-attach all wiring to the fan control knob and the piezoelectric igniter. Replace the access panel and tighten the two screws. Replace the control knobs.
- STEP 8** Remove the door, the logs, and the embers, noting the position of each log as it is removed.
- STEP 9** Remove the two screws holding the ember tray in place. Lift up the ember tray and remove.

- STEP 10** Remove the two burners. Mark each burner as to their location. Refer to FIGURE 4 and TABLE 3 for proper air shutter adjustment for each burner. Adjust each burner's air shutter to meet fuel conversion requirements. **NOTE:** Use the shank of an appropriately sized drill bit as an air shutter gauge. Pass the gauge through both sides of the air shutter, adjust and lock the shutter removing the gauge when finished making adjustments.
- STEP 11** Use a 3/8-inch (10mm) wrench to remove and discard the burner spud orifices. Place the new burner spud orifices in the appropriate location per the conversion kit instruction or refer to page 12 for the proper location of each labeled burner spud orifice.
- STEP 12** Remove and replace the pilot gas orifice located in the **PILOT FLAME DIFFUSER BODY**.
- Remove the pilot flame diffuser (FIGURE 25, Item B) by pulling up on it. The retainer clip (FIGURE 26, Item A) should release the pilot flame diffuser with a light pulling motion.
 - Remove the pilot gas orifice (FIGURE 10, Item F) by using a 5/32 hex head wrench (Allen wrench) placed in the top of the pilot gas orifice.
 - Verify the correct pilot gas orifice number per Page 11 kit definitions. Reinstall and tighten the new pilot gas orifice and replace the pilot flame diffuser by reinserting it into the retainer clip.

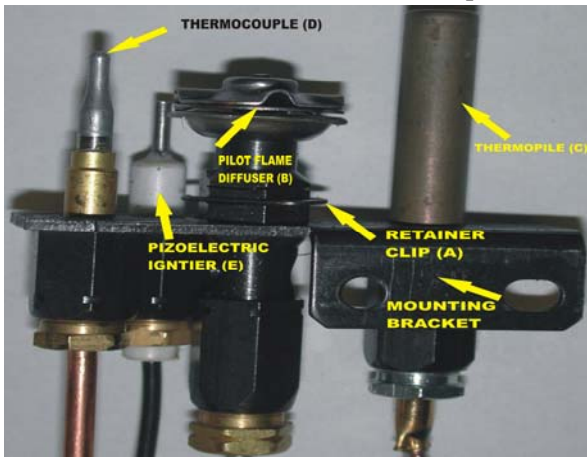

FIGURE 25: PILOT VALVE (back side)

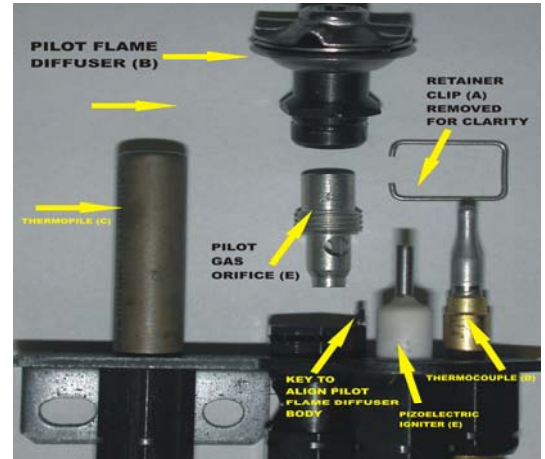

FIGURE 26: PILOT VALVE

- STEP 13** Refer to FIGURE 27, Note (X). The piezoelectric igniter cannot be installed incorrectly unless it is damaged. The piezoelectric igniter should be in a parallel plane to the pilot flame diffuser body. Each time the igniter button is pressed, a blue arc should occur from the piezoelectric igniter to the pilot flame diffuser body. Replace the burners, the ember tray, the logs, the embers, and the door, ensuring correct position of all components.

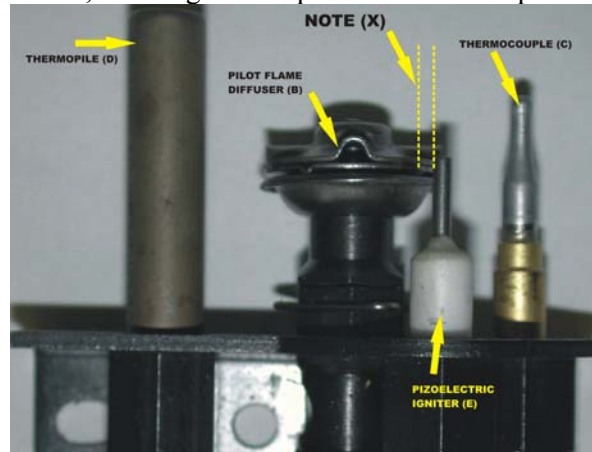

FIGURE 27: PILOT VALVE

STEP 14 Open the gas supply and perform gas leak test. One of the best methods used to check for gas leaks is soap bubbles. Soap bubbles are made by mixing liquid detergent with a little water and shaking vigorously to create soap bubbles. Cover the gas pipe joint or valve component with these soap bubbles. If soap bubbles grow in size or the bubbles are blown off the connection, a gas leak exists. Make necessary repairs and retest until no change in soap bubbles is seen at any joint or valve connection. **WARNING: DO NOT USE AN OPEN FLAME TO CHECK FOR GAS LEAKS**

STEP 15 Re-light the appliance. Check the flame control operation.

NATURAL GAS CONVERSION

If conversion is required from propane fuel to natural gas fuel, follow the same 15 steps listed in the section above using the proper Country Flame natural gas conversion kit. Adhere to the following:

NOTE: Conversion kits are to be installed by qualified service technicians.

NOTE: Do not install a kit IF conversion items are missing; check kit for all parts needed.

NOTE: A Torx T20 Tamper-Proof screwdriver may be ordered separately if needed.

THERMOSTAT/FAN CIRCUIT

The Inglenook gas log control valve is pre-wired to accept a millivolt wall thermostat. This remote thermostat can be used to turn the Inglenook gas log system on and off automatically. If additional airflow is desired, purchase an optional Inglenook blower kit, part number IN-6200, directly from Country Flame or one of its local authorized dealers. Follow the instructions provided with the blower kit. The blower will automatically turn on when the heat sensing thermo-disc closes. The fan speed is controlled by the rheostat speed control. Connect the wall thermostat to the terminal block on the control valve as shown in FIGURE 28 below. **CAUTION:** Label all wires prior to disconnecting them when servicing either the controls or the blower system. Wiring errors can cause improper and dangerous operational conditions. **ALWAYS** verify proper operation of the Inglenook gas logs, the control valve, the thermostat, and the optional blower after servicing is complete. If operational issues are noted after servicing is complete, **DO NOT USE THE Inglenook** until corrections are made.

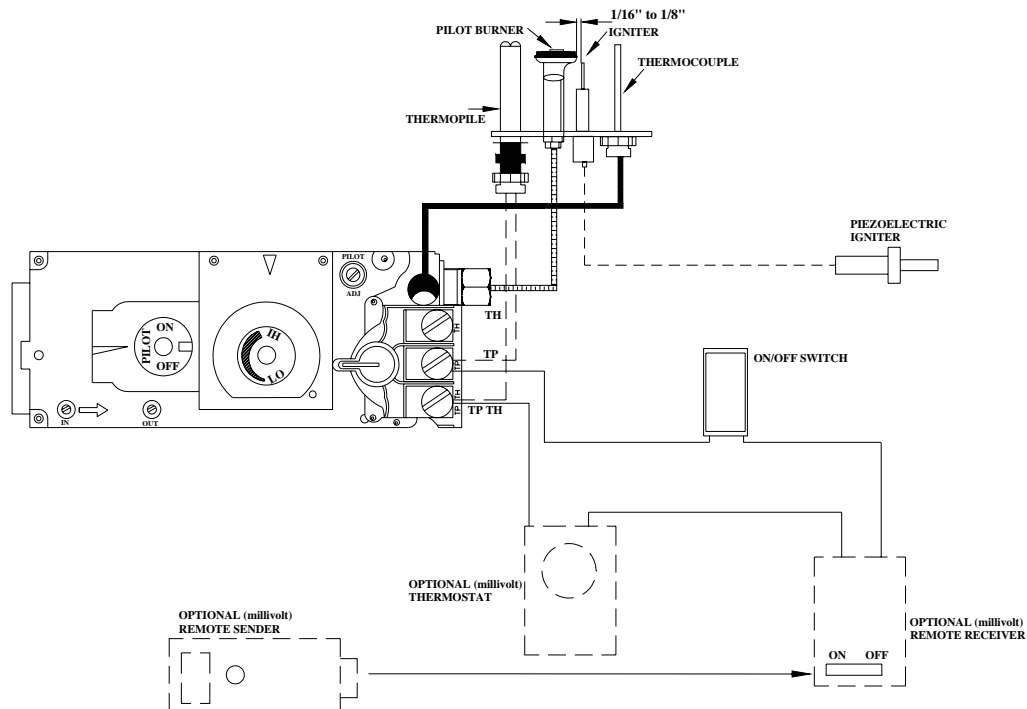

FIGURE 28: THERMOSTAT WIRING DIAGRAM

TROUBLESHOOTING INSTRUCTIONS

PROBLEM	POSSIBLE CAUSE	SOLUTION
Pilot will not light.	Air in gas lines	Refer to Item #1 of the Set-Up Guide.
	Defective spill switch.	Check for continuity across spill switch leads. Replace spill switch if excessive resistance is present or if circuit is electrically open.
	Wrong Inlet Pressure.	Refer to Item #2 of the Set-Up Guide.
	Defective piezo spark electrode.	Replace electrode if the insulator is cracked or the tip is corroded. Verify that the spark gap between the pilot and the electrode is correct.
	Defective piezo wire.	Replace piezoelectric igniter if its wire insulation is damaged or the wire is broken or corroded.
	Safety interlock function engaged.	Allow the thermocouple to cool until the mV drops below the hold-in requirements of the safety magnet, (30 seconds or less). Re-light pilot.
Pilot will not hold.	Wrong inlet pressure	Refer to Item #2 of the Set-Up Guide.
	Pilot adjustment screw not adjusted properly.	Refer to Item #7 in the Set-Up Guide.
	Thermocouple or thermopile not properly inserted into the pilot housing.	Refer to Item #3 in the Set-Up Guide.
	Thermocouple or thermopile has film build-up on tip.	With the thermocouple and thermopile tips cool, clean the upper 3/8" with a very fine emery cloth.
	Electrical resistance too high.	Using a very fine emery cloth, clean thermopile and thermocouple connections at valve. Tighten thermocouple into valve hand tight, plus ¼ turn with a wrench.
	Defective thermocouple. (mV Plus systems)	Verify that thermocouple is not kinked or damaged. Check open circuit voltage of thermocouple. Voltage should be between 18mV and 28mv. If voltage is less than 14mV, replace thermocouple.
	Defective thermopile. (Millivolt system)	Refer to Item #7 in the Set-Up Guide.
	Defective safety magnet. (mV Plus systems)	Verify operation of safety magnet in the following manner. Depress and hold pilot button. Verify open-circuit thermocouple voltage as described in previous step. Reconnect thermocouple to valve. Measure the voltage between the solder button on the base of the safety magnet, and the valve body. If the mV reading is above 6mV for vented appliances, or 8.5mV for un-vented appliances and the safety magnet does not hold, replace the valve. If closed circuit mV reading is the same as the open circuit reading, the coil is electrically open. Replace the valve.
	Defective Safety Magnet (Millivolt system)	Verify operation of safety magnet in the following manner. Remove all wires from the terminals of the main operator. Measure the electrical voltage between the terminals TPTH and TP. If the voltage is above 110mV and the safety magnet does not hold, replace the valve.
	Pilot orifice blocked.	Replace orifice with a new orifice of the exact size and type.
Pilot light drops out.	Wrong pilot orifice installed in pilot light.	Replace the orifice with a new orifice supplied specifically for the appliance and gas type in question.
	Spill switch activated.	Examine the venting system. Repair as necessary.

TROUBLESHOOTING INSTRUCTIONS (cont'd)

PROBLEM	POSSIBLE CAUSE	SOLUTION
No gas to main burner. Thermostat or wall switch will not cycle main burner	Gas pressure to appliance is low.	Refer to Item #2 in the Set-Up Guide.
	Pilot not lit.	Light pilot and wait for thermopile to heat up sufficiently to power the main operator. If pilot fails to light, or hold, refer to above sections.
	Control knob not in ON position.	Rotate OFF/PILOT/ON control knob to the ON position.
	Thermostat not in the ON position.	Turn thermostat to ON, and adjust temperature control to call for heat.
	Thermopile output voltage not within design parameters.	Refer to Item #7 in the Set-Up Guide. If unable to meet minimum thermopile requirements, replace thermopile.
	Defective thermostat or thermostat wiring.	(A) With the pilot adjusted properly, (Refer to Item #7 in the Set-Up Guide) place a jumper wire between TPTH and TH. Measure the voltage (millivolt) reading across the TPTH and TP terminals on the control valve. This voltage should not fall below 300mV. Record reading. (B) Remove the jumper wire from the TPTH and TH connections and reconnect the thermostat wires to the same terminals. Measure the voltage (millivolt) reading across the TPTH and TP terminals on the control valve. This voltage should not fall below 150mV. If reading is below 150mV the source of excessive resistance must be located and removed. (bad connections or bad wires)
	Defective wall switch.	Repeat the troubleshooting items covered under "Defective thermostat or thermostat wiring," Use the exact same procedures but substitute the word "wall switch" where the word thermostat appears.
	Excessive wire resistance.	Make certain that all mV connections are made using wire of the proper AWG size. (Refer to the Trouble-Shooting Guide.)
Valve wired wrong.	Thermopile leads must be connected to the TPTH and the TP connection of the main control valve. Thermostat wires must be connected to the TPTH and the TH terminals of the main control valve.	
	Main operator coil defective.	Verify the electrical resistance of the main control valve operator coil in the following manner: (A) Remove all wires from the control valve head. (B) With an ohmmeter, measure the electrical resistance between TP and TH terminals. If the resistance does not fall within specifications shown in the Troubleshooting Guide, replace valve.
Main burner cycles on and off. System not on thermostat.	Flue gas spillage present in combustion chamber. (Non-DV appliances only)	Check the appliances installation instructions provided by the manufacturer to verify that the proper flue dimensions are within specification and that proper combustion make-up air is provided for the particular appliance.
		Verify that the appliance's flue ins installed according to manufacturer's instructions.
		Check the flue or the combustion air intake for blockage. Clean as necessary.
Main burner lights in the PILOT position of the control valve.	Debris or damage to seat of main valve.	Replace the control valve assembly.
	Main seat blown out because of exposing LPG gas valve to unregulated line pressure in excess of 15 psig.	Replace the control valve assembly.

TROUBLE-SHOOTING GUIDE

The 820 Nova millivolt control valve is available in three different configurations. They are the (1) **Millivolt Plus vented**, or the (2) **Millivolt Plus vent-free**, or the (3) **Millivolt** systems.

The **Millivolt Plus vented** system is for use in direct vent appliances that require fast shut-off in the event of a pilot flame failure. A thermocouple powers the safety magnet and a thermopile powers the main control valve.

The **Millivolt Plus vent-free** system is used in conjunction with an ODS pilot. As with the vented Millivolt Plus control valve, this valve uses a thermocouple to power the safety magnet and uses a thermopile to power the main control valve.

The **Millivolt** system is used with gravity vented appliances where rapid shut-off is not necessary in the event of a pilot flame outage. It uses a single thermopile to power both the safety magnet circuit and the main control valve. A spill switch could be used in the safety magnet circuit of this system.

All NOVA control valves are fitted with a safety interlock device that prevents unsafe ignition of the pilot burner after the ON/PILOT/OFF control knob is turned to the OFF position. All three of these control valves can accommodate a wall switch, or a wall thermostat, or a remote control unit that can be used to cycle the main control valve on and off. Following is the electrical data for the 820 Nova millivolt gas control valve models:

VALVE TYPE	MAIN CONTROL VALVE		SAFETY MAGNET	
NOVA mV Plus Vented	Minimum Voltage	145 mV	Hold-in current	Less than 285mA
	Coil Resistance	2.25Ω±0.5Ω	Drop-out current	Greater than 125mA
			Coil resistance	0.018Ω±0.003Ω
NOVA mV Plus Un-vented	Minimum Voltage	145 mV	Hold-in current	Less than 200mA
	Coil Resistance	2.25Ω±0.5Ω	Drop-out current	Greater than 80mA
			Coil resistance	0.018Ω±0.003Ω
NOVA Millivolt Vented	Minimum Voltage	145 mV	Hold-in current	Less than 12mA
	Coil Resistance	2.25Ω±0.5Ω	Drop-out current	Greater than 4mA
			Coil resistance	10.2Ω±0.05Ω

All millivolt control valve circuits are easily affected by electrical resistance. If enough resistance is present in the appliances circuit, two things can occur. (A) Either the main control valve will work intermittently and be unpredictable or (B) the main control valve will not work at all. There are several areas where excess resistance can be found in the appliances circuit. In new installations, the thermostat itself can be found to be the problem. Always use a thermostat rated for millivolt control as they have been designed to minimize circuit resistance. The other area to check is the wiring itself. Wire gage plays an important part in wire resistance. The smaller the diameter of the wire and the greater the length of the wire, the larger the circuit resistance will be. The table above provides valuable information to select the proper wire that is used to connect to the main control valve. This table refers to the total length of wire from the control valve out to the thermostat and back to the control valve. All electrical connections must be tight, clean, and free from corrosion. Corrosion can build up over time due to humidity problems so inspect wire connections on an annual basis.

WIRE SIZE	MAXIMUM LENGTH		WIRE SIZE	MAXIMUM LENGTH
12 Gauge	150 feet		18 Gauge	40 feet
14 Gauge	100 feet		20 Gauge	25 feet
16 Gauge	64 feet		22 Gauge	16 feet

NOVA mV SET-UP GUIDE

The following information is provided to assist in the set-up of the 820 NOVA mV control valve. A certified professional should install, perform conversions, and verify the proper operation of all Country Flame gas appliances. If there are any questions, please contact a local authorized dealer or Country Flame direct for assistance.

1. Bleed all air from gas lines before starting the system.
2. With the main burner in operation, adjust the inlet pressure regulator to supply gas to the appliance within the design parameters of the appliance as dictated by site-specific requirements. (Typically 7" W.C. NG and 11" W.C. LPG.)
3. Make certain that the thermocouple and thermopile are fully inserted and tightened into their respective holders in the pilot head. The thermocouple should be threaded into the valve hand-tight, and ¼ turn of the wrench.
4. Verify that the system is wired properly and that all connections are clean and tight. Thermopile leads are to be connected to the TPTH and TP connections of the main control valve. Thermostat and wall switch wires are to be connected to the TPTH and the TH terminals of the main control valve.
5. Turn the OFF/PILOT/ON control knob to the PILOT position and depress the knob while lighting the pilot with a match or the piezoelectric igniter switch.
6. Continue to hold the OFF/PILOT/ON control knob in (depressed) until enough current is generated by the thermocouple to engage the safety magnet. Remember: the Millivolt Plus system uses a thermocouple to power the safety magnet and the Millivolt system utilize power from a single thermopile to engage the safety magnet.
7. After the pilot flame has been lit for approximately three minutes and with only the thermopile wires connected to the main control valve, measure the voltage across the TPTH and TP terminals. The open circuit voltage should read between 500mV and 750mV. Adjust the pilot adjustment screw until the voltage reading falls within these parameters. (Counterclockwise increases the voltage reading and clockwise decreases the voltage reading.)
8. With the pilot flame adjusted properly, place a jumper wire between the TPTH and the TH connections. Take a voltage reading across the TPTH and the TP terminals on the main control valve. This closed circuit voltage should remain above 300mV.
9. Remove the jumper wire used in Step 8 that was connected from the TPTH and TH terminals and reconnect the thermostat and wall switch wires to the same terminals. Take a closed circuit voltage reading as described in Step 8. This closed circuit voltage reading should remain above 175mV.
10. Rotate the OFF/PILOT/ON knob to the ON position. The main burners should light.
11. Verify the operation of the thermostat and wall switch by cycling each individually. Observe the operation of the main burner during the cycling of the thermostat and wall switch.
12. Rotate the OFF/PILOT/ON knob to the OFF position. Both the pilot flame and the main burner flames should be immediately extinguished.
13. Refer to the wiring diagrams provided in this manual as needed.

SAFETY LABEL

GAS FIRED DECORATIVE APPLIANCE
APPROVED FOR UNITED STATES & CANADA
ANSI -Z21.60-2003

SERIAL NO. [REDACTED]

MANUFACTURED BY:
COUNTRY FLAME TECHNOLOGIES
A DIVISION OF AMERICAN PRODUCTS, LLC
MARSHFIELD, MISSOURI

MODEL:	IN-GLS-24N For use with Natural Gas	IN-GLS-24P For use with Propane
Maximum Input (0'-2000')	65,000 BTUH	65,000 BTUH
Minimum Input (0'-2000')	42,600 BTUH	43,000 BTUH
Orifice (DMS) (0'-2000'), Front/Rear	31/43	48/55
Maximum Input (2000'-4500')	59,000 BTUH	58,700 BTUH
Orifice (DMS) (2000'-4500'), Front/Rear	32/44	49/56
Manifold Pressure	3.5" w.c.	10.0" w.c.
Manifold Pressure, Low setting	1.4" w.c.	4.2" w.c.
Minimum Inlet Pressure	5.0" w.c.	11.0" w.c.
Maximum Inlet Pressure	14.0" w.c.	14.0" w.c.

NOT FOR USE WITH SOLID FUELS

THIS APPLIANCE IS EQUIPPED FOR USE WITH
 NATURAL GAS PROPANE

THE GAS APPLIANCE PRESSURE REGULATOR
 MUST BE SET FOR THE GAS WITH WHICH THE
 APPLIANCE IS USED.

THIS APPLIANCE IS DESIGNED AND TESTED FOR
 USE ONLY IN AN INGLENOOK MODEL #IWZC-02.

**WARNING: THE INGLENOOK DAMPER MUST BE
 PERMANENTLY OPENED DURING THE USE OF
 THIS APPLIANCE.**

CERTIFIED BY:



LABEL # 35-0400-05



FIGURE 29: CONTROL PANEL OVERLAY

REPLACEMENT PARTS – INGLS 24N or INGLS 24P

When requesting service or replacement parts for your fireplace, please provide model number and serial number. All parts listed in this manual may be ordered from an authorized dealer.

PART	PART DESCRIPTION	PART NUMBER
Figure 30, Item 1	EMBER TRAY ASSEMBLY	IN-6529
Figure 30, Item 2	BACK BURNER ASSEMBLY	IN-6505
Figure 30, Item 3	FRONT BURNER ASSEMBLY	IN-6506
Figure 30, Item 4	GAS VALVE PLATE ASSEMBLY	IN-6528
Figure 30, Item 5	GRATE ASSEMBLY	IN-6520
Figure 30, Item 6	CONTROL PANEL FACEPLATE	IN-6527
Figure 15 -21, Item 7	LOG SET	IN-6521
Figure 14, Item 8	EMBERS	IN-6526
	ON/OFF PILOT EXTENSION KNOB	IN-6522
	HI/LOW EXTENSION KNOB	IN-6523
	PIEZO IGNITER	IN-6525
Item 9	MODEL #1650 N DORMONT FLEX CONNECTOR GAS LINE	IN-6530
Table 2a	CONVERSION KIT (to propane)	IN-6503
Table 2b	CONVERSION KIT (to natural gas)	IN-6504
	GAS VALVE (CNG)	GC-3905
	GAS VALVE (LPG)	GC-3906

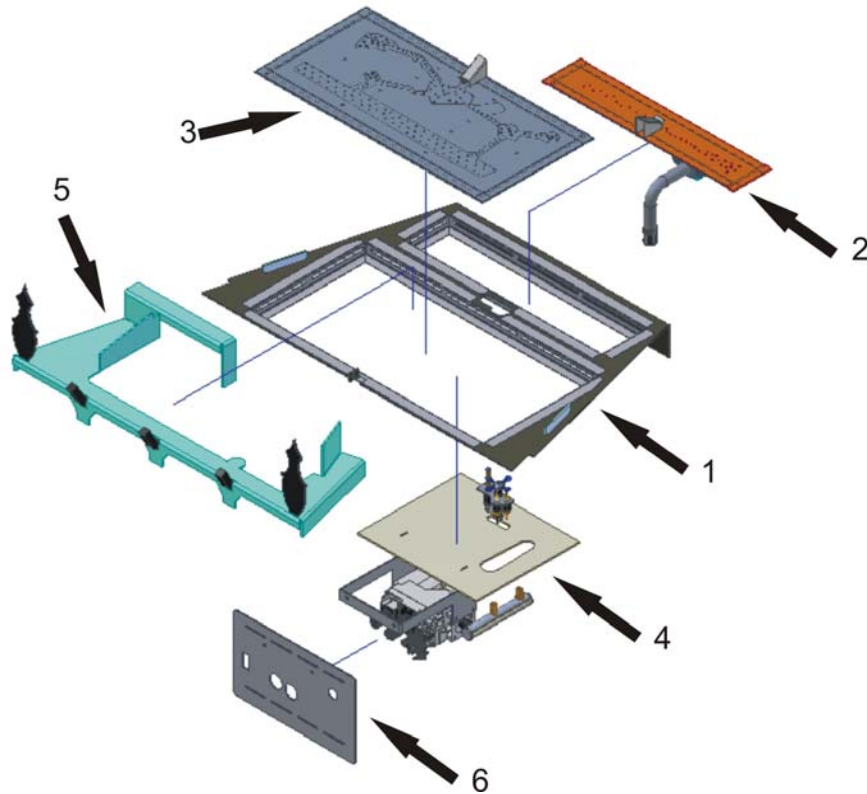

FIGURE 30: INGLENOOK GAS LOG PARTS

LIMITED 10 YEAR WARRANTY

To establish warranty dates a completed warranty card must be received at Country Flame Technologies, 900 George Street, Marshfield, MO 65706, within 60 days of the date of original retail purchase of the Inglenook gas log set. Failure to provide this warranty card within the timeframe specified may require the original retail purchaser to prove the date of installation before any warranty work can be performed.

The warranty exclusions and limitations of liability are effective upon installation of the fireplace.

Subject to the conditions set forth herein, Country Flame Technologies extends the following warranty with respect to Country Flame Inglenook Gas Products.

If Country Flame Technologies is reasonably satisfied that any part or portion of the fireplace covered by this Limited Warranty is defective in material or workmanship under normal use and service as described in the Operating Instructions, Country Flame Technologies will take the following actions:

1. If the defect is reported during the first year from the date of installation (stainless steel burners and fiber logs are covered for 2 years), Country Flame Technologies will replace or repair the defective components at its sole expense. The decision whether to replace a component will be made at Country Flame Technologies' sole discretion. Country Flame's Limited Warranty does not cover components broken during shipping, misuse or careless handling. Country Flame Technologies shall not be responsible for any indirect, incidental, or consequential damages or for any costs other than those incurred by Country Flame Technologies to repair or replace the defective component. If components (including venting) other than factory-approved components are used, all warranties on the Inglenook fireplace system are voided. **Defects reported after the first year will not be covered by warranty unless they fall within the purview of paragraph 2 or 3 below.**
2. If the following defects are reported during the second year after the date of installation, Country Flame Technologies will supply replacement parts at the current wholesale price: defective electrical or manual components, optional components or accessories (not including glass panels broken during misuse or careless handling). Country Flame Technologies shall not be responsible for any labor, transportation or other costs. Furthermore, Country Flame Technologies will not be liable for any indirect, incidental or consequential damages.
3. Country Flame Technologies will replace or repair defective burners, burner associated parts, decorative log grates, or other steel components, at anytime during ten (10) years from the date of original installation. The decision whether to replace or repair the defective component shall be made at Country Flame Technologies' sole discretion. Country Flame Technologies shall not be responsible for any indirect, incidental or consequential damages or for any costs other than those incurred by Country Flame Technologies to repair or replace the defective component.

This Limited Warranty is the exclusive remedy available to you. If Country Flame Technologies cannot effectively resolve a warranty problem in an expedient and cost-effective manner, it can discharge its entire warranty liability by refunding the price of the product to you.

Products made by other manufacturers, whether sold with the Inglenook fireplace or added thereafter, are NOT covered by this Limited Warranty. The use of other unauthorized components will make this warranty null and void. This Limited Warranty will also be void if the Inglenook or any of its components are not installed by a qualified installer in accordance with the Installation Instructions. Furthermore, the Limited Warranty will be void if the fireplace is not operated, at all times, and according to the Operating Instructions furnished with the fireplace. Any service work must be performed by authorized service representatives.

EXCEPT TO THE EXTENT PROVIDED BY LAW, NO OTHER EXPRESS OR IMPLIED WARRANTIES, INCLUDING WARRANTIES OF MERCHANTABILITY OR FITNESS FOR A PARTICULAR PURPOSE, SHALL APPLY TO THE FIREPLACE PRODUCT. In States that do not allow limitations on how long an implied warranty lasts, or do not allow exclusion of indirect damages, those limitations or exclusions may not apply to you. You may also have additional rights not covered in this Limited Warranty.

Country Flame Technologies reserves the right to make changes at any time, without notice, in design, material, specifications and prices. It also reserves the right to discontinue styles and products.